

Tools Needed

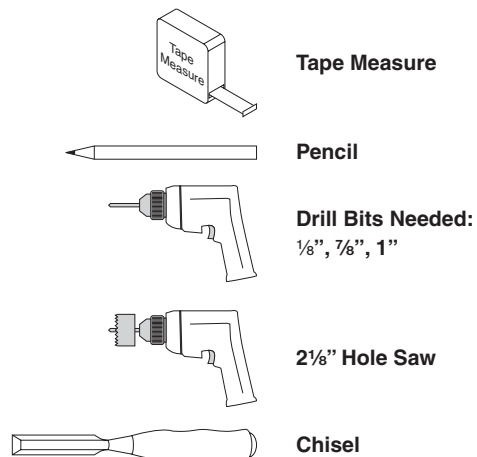

1 Measure Door Width

If the door is thinner than 1 3/8" or thicker than 1 3/4", then the lock will not fit properly on the door.

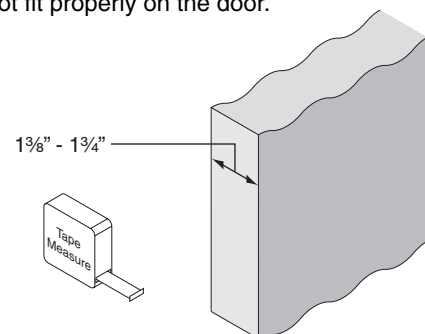

2 Mark Lock Centerline on Door Face and Door Edge

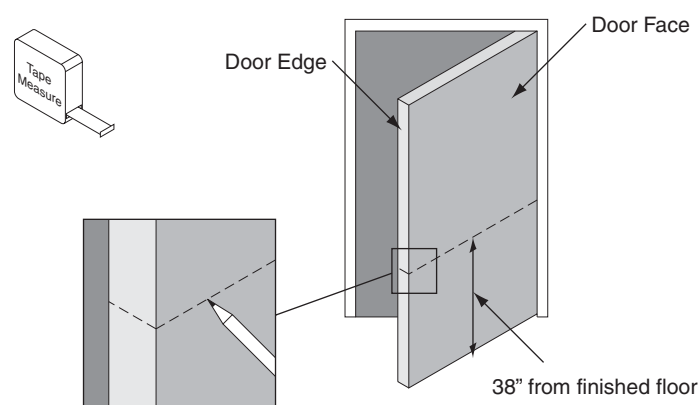

3 Mark and Drill Hole in Door Face with 2 1/8" Hole Saw

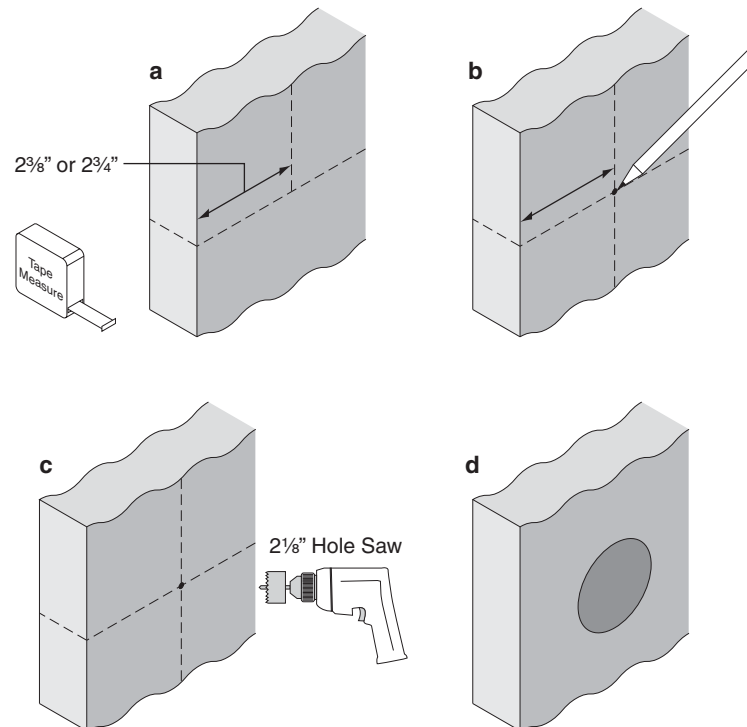

4 Mark and Drill Hole in Door Edge

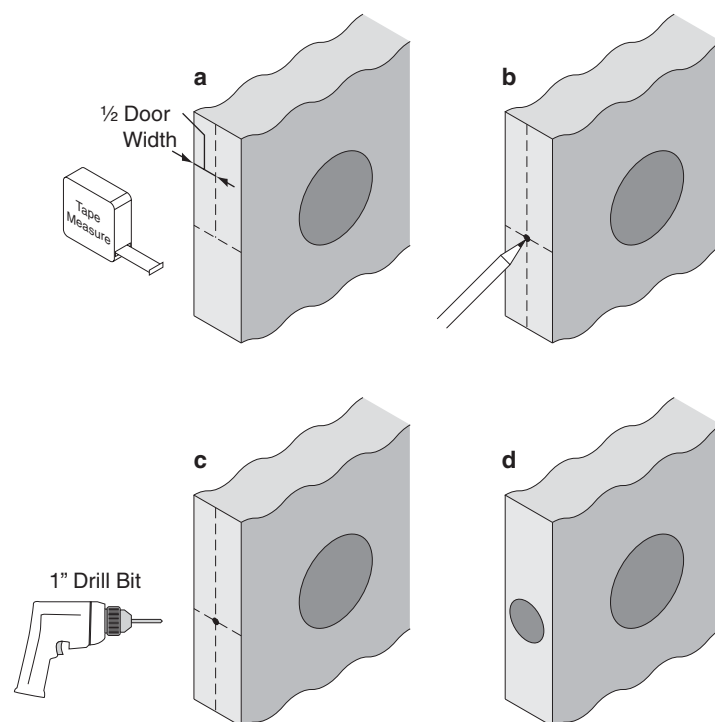

5 If Necessary, Mortise for Latch

- Insert latch into door edge hole.
- Use pencil to trace latch and mark holes.
- Remove latch and drill two 1/8" pilot holes.
- Use chisel to create latch mortise.

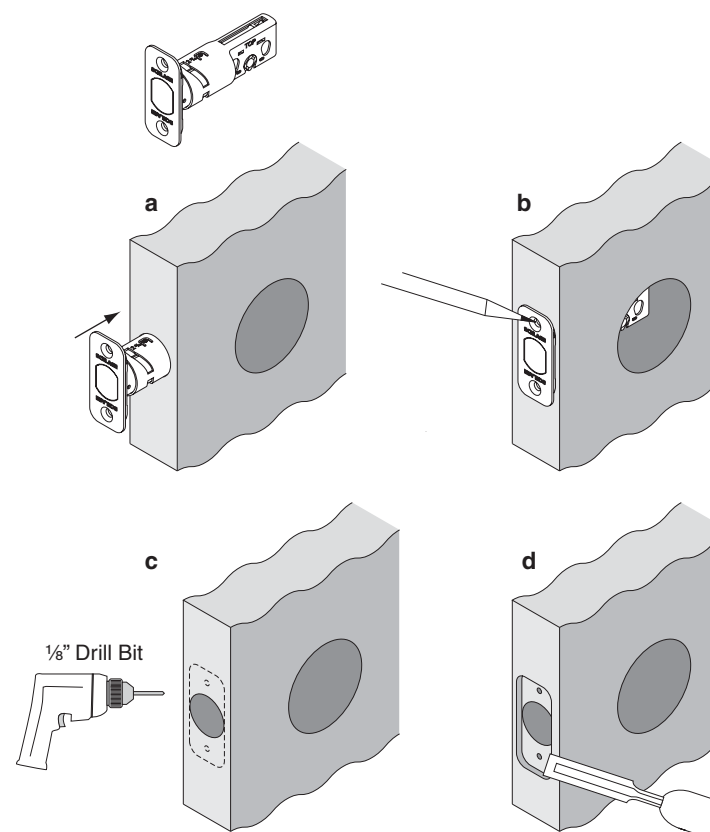

6 Measure and Mark Door Jamb for Strike

- Measure 38" from finished floor and mark on door jamb.
- Mark center for strike hole exactly opposite latch hole.

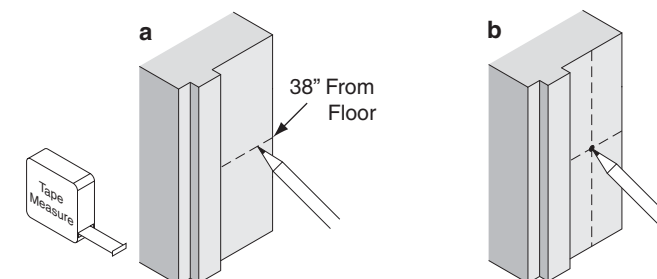
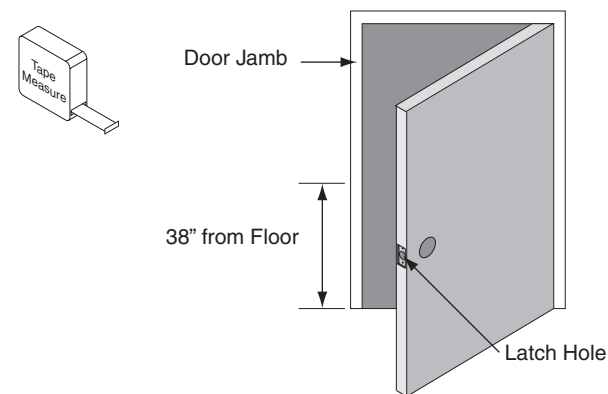

7 Mark and Drill Holes for Strike

- Drill two (2) 1" holes, 1/4" deep, as shown. Chisel out excess material.
- Line up strike box and strike with hole in door jamb.
- Use pencil to trace strike and mark holes.
- Drill five (5) 1/8" pilot holes and use chisel to create strike mortise.

