

AccuLink™ Remote Thermostat

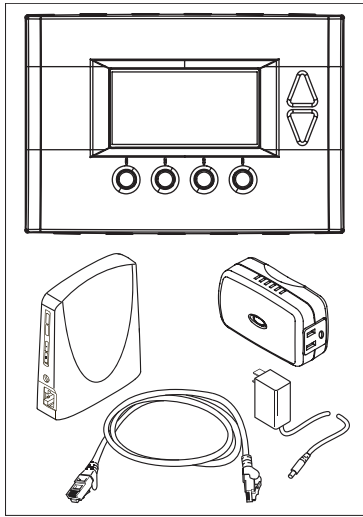

AZTSK500BB32MA

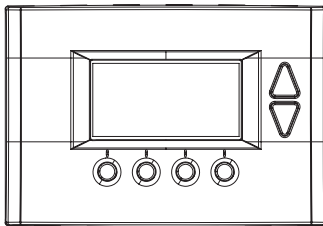

AZEMT500BB32MA

AZTSK500BB32MA

- American Standard AccuLink™ Remote Thermostat Kit
- Includes AZEMT500BB32MA thermostat, Schlage Bridge and RP100BX appliance module
- Remote access to thermostat from computers connected to internet and compatible web enabled mobile devices including Android™, Blackberry™, iPhone™ and many other web enabled phones
- Air conditioning and heating energy management
- Easy Installation and Set-Up
- Expandable for home management

Application:

- 3 Heat/2 Cool for Heat Pump
- 2 Heat/2 Cool for Gas Electric
See AZEMT500BB32MA for details
- Use with additional AZEMT500BB32MA thermostat
- Use with additional RP200R light module and RP100BX Appliance Module
- Use with Schlage LiNK Deadbolt and Lever Locks
- Up to 231 devices may be wirelessly connected to one Schlage Bridge

Dimensions:

- Thermostat: 5.7" W x 4.0" H x 1.2" D
- LCD display 2.75" W x 1.5" H
- Shipping Weight: 2.35 lbs.

AZEMT500BB32MAA

- 24 Vac, Z Wave enabled thermostat
- Compatible with Schlage LiNK
- 7 day programmable, 4 schedules per day, may be scheduled from web or thermostat
- Remotely adjust thermostat and view temperature from computers connected to internet and compatible web enabled mobile devices including Android™, Blackberry™, iPhone™ and many other web enabled phones
- Requires Schlage Bridge and Appliance Module for remote access
- Service fee required for remote access
- Thermostat Recovery
- Remote Sensing
- Dual Fuel control capable
- Built in humidity sensor
- Dehumidification control
- Enhanced dehumidification with variable speed indoor products
- Filter service reminder alert
- Maintenance reminder alert
- Out of Range Temperature alert
- Keypad tamper alert
- Alerts may be sent by e-mail and/or text to mobile device
- Limited Five Year Parts Warranty
- Registered Ten Year Parts Warranty

Application:

- 3 Heat/2 Cool for Heat Pump
- 2 Heat/2 Cool for Gas Electric
- 7 day programmable, 4 schedules per day
- Used with Schlage Bridge and Appliance Module, included in AZTSK500BB32MA kit

Compatible Systems

- Gas/Oil Furnace
 - Air Handler/Electric Furnace
 - Heat Pump systems
 - Cooling systems
- May be Compatible**
- Conventional Boilers
 - Geothermal
 - 24 Vac Forced Air Multi Zone Systems

Not Compatible

- Radiant Floor
- 120/240 Volt Electric Baseboard Heat
- Wall Heating systems
- Proprietary Communicating Systems

Dimensions:

- 5.7" W x 4.0" H x 1.2" D
- LCD display 2.75" W x 1.5" H
- Shipping Weight: 1 lb.

Schlage LiNK™ Accessories

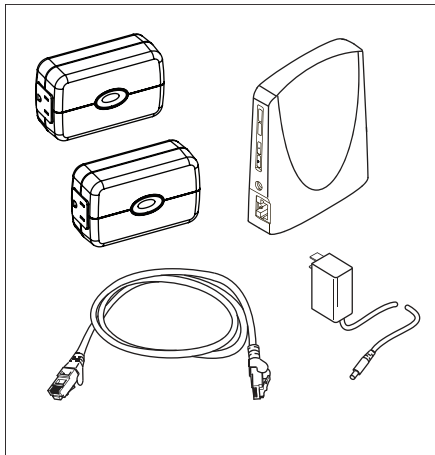

SZLSK100AA

SZLSK100AA

- Home Automation Kit
- Includes Schlage Z-Wave to broadband bridge, two RP100BX appliance modules, ethernet cable, and power supply
- Remote appliance control from any PC with internet access and most internet enabled devices and smart phones
- Secure Connection with server for homeowner protection
- Easy Installation and Set-Up

Application:

- Use with AZEMT500BB32MA
- Use with additional RP200R light module and RP100BX Appliance Module
- Use with Schlage LiNK Deadbolt and Lever Locks

Dimensions:

- Bridge: 4.0" W x 4.8" H x 1.4" D
- Appliance Module: 4.0" W x 2.4" H x 1.6" D
- Shipping Weight: 2 lbs.



RP200R

RP200R

- Signal Repeater and Dimmer Light Module
- Used to control and dim plug-in incandescent lighting

Application:

- Use with Schlage Bridge (included in AZTSK500BB32MA kit)
- Max load both outlets = 15 Amps, 1800 Watt resistive
- Max load Z Wave controlled outlet = 300 Watts incandescent only
- Shipping Weight: 1 lb.



RP100BX

RP100BX

- Signal Repeater and Appliance Module
- Used to control small appliances and plug-in incandescent, fluorescent, and LED lighting. On/Off control
- May be used to control/reduce standby loss from plug-in power supplies and small electronic loads

Application:

- Use with Schlage Bridge (included in AZTSK500BB32MA kit)
- Max load both outlets = 15 Amps, 1800 Watt resistive
- Max load Z Wave controlled outlet = 600 Watts incandescent, 1/2 HP, 1800 Watt resistive
- Shipping Weight: 1 lb.

Schlage LiNK™ Accessories

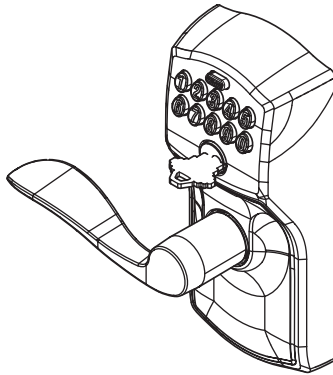

BAY599BBALLFEA
BAY599SNALLFEA
BAY599ABALLFEA

BAY599 (Lever Lock)

- Schlage wireless locks can be added to a the Z-Wave network within your home
- Remotely lock or unlock the door from computers connected to internet and compatible web enabled mobile devices including Android™, Blackberry™, iPhone™ and many other web enabled phones
- Confirm lock status from internet enabled computer or web enabled mobile device
- Assign up to 19 personalized 4 digit codes for each member of your household
- Up to 3 year battery life
- Provides battery level status at the lock and on the web
- Available in 3 finishes: Bright Brass, Satin Nickel, Aged Bronze
- Class 2 rated door lock
- Lifetime limited mechanical and finish warranty
- 1-year limited electronics warranty

Model number and finish:

- BAY599BBALLFEA - Bright Brass
- BAY599SNALLFEA - Satin Nickel
- BAY599ABALLFEA - Aged Bronze

Application:

- Use with Schlage Bridge (included in AZTSK500BB32MA kit)
- Carton Size: 6" x 7.75" x 9.56"
- Shipping Weight: 5.5 lbs.

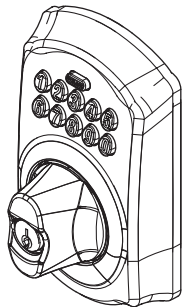

BAY369BBADBEEA
BAY369SNADBEEA
BAY369ABADBEEA

BAY369 (Deadbolt)

- Schlage wireless locks can be added to the Z-Wave network within your home
- Remotely lock or unlock the door from computers connected to internet and compatible web enabled mobile devices including Android™, Blackberry™, iPhone™ and many other web enabled phones
- Confirm lock status from internet enabled computer or web enabled mobile device
- Assign up to 19 personalized 4 digit codes for each member of your household
- Up to 3 year battery life
- Provides battery level status at the lock and on the web
- Available in 3 finishes: Bright Brass, Satin Nickel, Aged Bronze
- Class 2 rated door lock
- Lifetime limited mechanical and finish warranty
- 1-year limited electronics warranty

Model number and finish:

- BAY369BBADBEEA - Bright Brass
- BAY369SNADBEEA - Satin Nickel
- BAY369ABADBEEA - Aged Bronze

Application:

- Use with Schlage Bridge (included in AZTSK500BB32MA kit)
- Carton Size: 5.75" x 7.93" x 8.5"
- Shipping Weight: 6 lbs.

Schlage LiNK™ Accessories

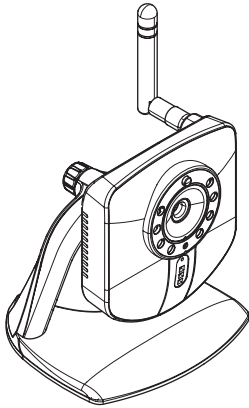

WCW100NNSL

WCW100NNSL

- LiNK™ Web Camera - Wireless
- Indoor, fixed camera
- Remotely monitor your home from any PC with internet access and most internet enabled devices and smart phones
- Secure Connection with server for homeowner protection
- Plug and Play with Schlage LiNK™ System
- Privacy button

Application:

- VGA (640x480) resolution
- Operating Temp -5C to 50C
- Wireless
 - 802.11b/g
 - WEP 64/128, WPA-PSK, WPA2

Dimensions:

- 3.8" W x 3.5" H x 1.4" D
- Shipping Weight: 1 lb

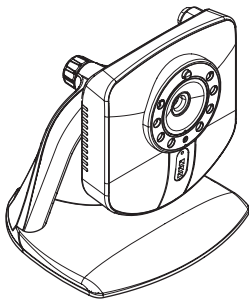

WCE100NNSL

WCE100NNSL

- LiNK™ Web Camera - Wired
- Indoor, fixed camera
- Remotely monitor your home from any PC with internet access and most internet enabled cell phones
- Secure Connection with server for homeowner protection
- Plug and Play with Schlage LiNK™ System
- Privacy button

Application:

- VGA (640x480) resolution
- Operating Temp -5C to 50C

Dimensions:

- 3.8" W x 3.5" H x 1.4" D
- Shipping Weight: 1 lb

Remote Sensors

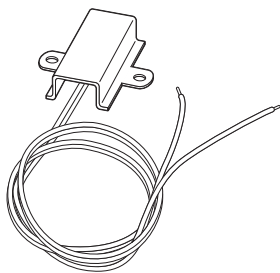

BAYSEN01ATEMPA

- Outdoor Temperature Sensor for Use with AZEMT500BB Thermostats
- Accuracy
+/- 1.5°F over 32°F to 100°F
- Display Range
-40°F to 140°F

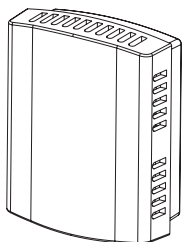

ZZSENSAL0400AA

- Indoor Sensor for Use with AZEMT500BB Thermostat
- Operating Ambient Temperature Range: 20° to 120°F (-6.7° to 48.9°C)
- Display Range: 20° to 120°F (-6.7° to 48.9°C)
- Sensor Accuracy: +/- .5°F at 75°F
- Operating Relative Humidity: 5% to 90% non-condensing

Dimensions in in. (mm):

- 1.54 (39)w x 1.93 (49)h x .625 (1.6)d
- Storage Temperature: -40° to 140°F (-40° to 60°C)
- Finish: White